

NX CMM Inspection Programming Add-on

Benefits

- Dramatically reduce programming time (up to 80 percent reduction)
- Ensure all part requirements are inspected according to company standards
- Capture and share best practices
- Create programs offline without using a physical part or machine
- Facilitate fast and efficient design change propagation across entire process
- Simplify software deployment footprint (single system for CAD, CAM and CMM)
- Minimize training requirements
- See and evaluate "as-built" compared to "as-designed"
- Find possible causes of tolerance failure

Summary

The NX CMM Inspection Programming Add-on provides the full CMM Inspection capabilities when combined with a combination NX CAD/CAM Package. These packages provide much of the underlying support functions of the full CMM Inspection product. So for customers who own these combination CAD/CAM packages, they can optionally obtain the full CMM Inspection Programming solution via this Add-on.

NX™ software's CMM Inspection Programming capabilities provide a state-of-the-art solution for offline programming that reduces programming time, frees up expensive CMM machine resources and ensures fast responses to design changes. The included data analysis brings measured data back into the programming environment for comparison and study. By combining

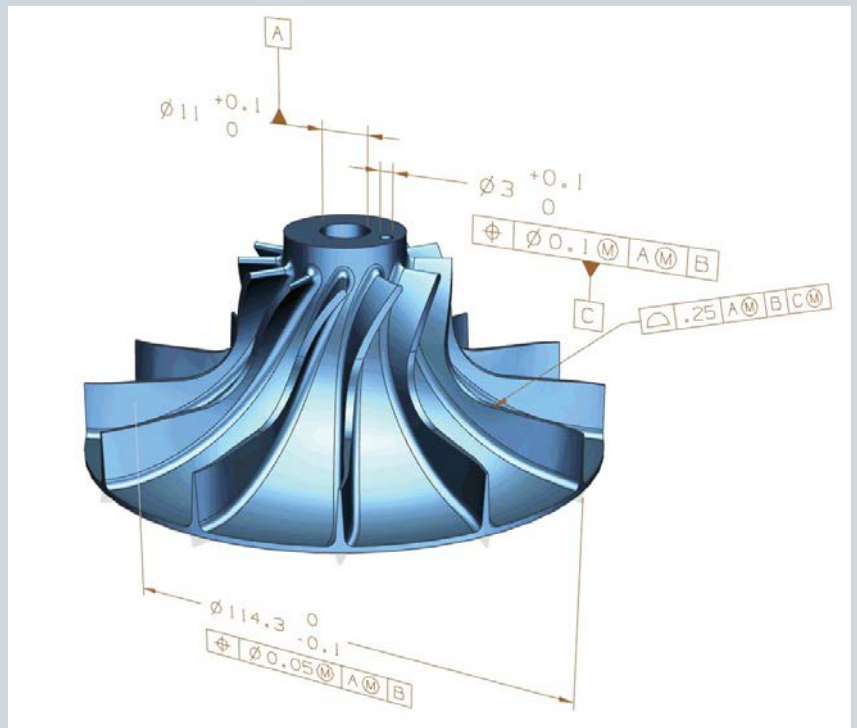

Automate creation of inspection programs by using PMI on CAD model.

NX

www.siemens.com/nx

SIEMENS

NX CMM Inspection Programming Add-on

Features

- Ability to automatically create programs from PMI
- Collision prevention
- Machine simulation and program verification
- Embedded probe and machine models
- Ability to easily create own probes and machines
- DMIS 5.2 output
- Ability to create custom postprocessors for specific CMM languages
- Associativity for rapid design change updates
- Ability to manage program revisions with Teamcenter
- Data analysis capability displays measurements
- Measurements displayed in navigator and linked to graphics
- Measured data read back in as .mea or .dml files

industry knowledge and best practices with process automation, NX CMM Inspection Programming streamlines the entire CMM inspection program development and measurements analysis process. The process spans feature definition and path creation to program generation and validation, and ultimately to analysis of measured data. Integration with Teamcenter® software ensures that the correct revisions of parts are programmed and executed on the shop floor.

Automate inspection programming to save time and improve accuracy

NX CMM Inspection Programming enables you to use streamlined workflows to minimize ramp-up time and quickly generate collision-free programs. You can reduce nonconformance and ensure accuracy to design requirements by programming directly on the CAD model.

By using product and manufacturing information (PMI) on the model (including GD&T and 3D annotations) to automatically generate programs, you are well positioned to guarantee completeness. You can further automate the programming process by applying your own standard inspection path methods, tools and project templates.

Program definition

Manual program creation can be leveraged to rapidly create highly accurate inspection programs directly from a 3D solid CAD model.

Automatic program generation lets you automatically generate inspection features, tolerances and inspection paths from PMI on the CAD model, even across multiple features. Collision avoidance methods identify interferences and automatically resolve them.

DMSC 5.2 certification ensures reliable programs that meet latest standards from the Digital Measuring Standards Consortium.

Use included probe and machine models or create your own probes/models.



Program validation

Tolerance application automatically checks all tolerances to ensure that they are correctly applied to their associated features.

Collision prevention enables you to identify and eliminate collisions before sending programs to your machines.

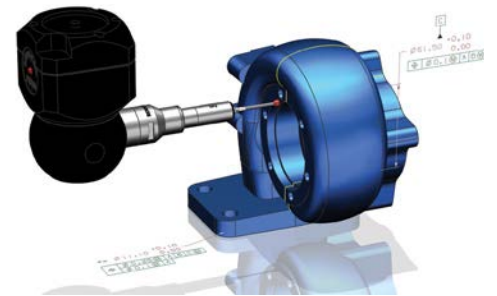

Generate collision-free programs directly from CAD model.

CMM machine simulation can be used to run kinematic model-based simulations of the machine to verify that all features are reachable, as well as to verify that machine limits are not exceeded. 5-axis scans show the probe orientations during preview.

Program output

DMIS output enables you to output DMIS out-of-the-box.

Customized output enables you to write custom postprocessors using the TCL language to generate programs for specific CMM languages.

Re-use of company standards

Probes and CMM machines provide you with the option of using included machine models or created models of your own when producing specific CMMs for simulation and fixture design. You can use these capabilities to easily assemble probe components and define tip geometry. You can use your own models or the included Renishaw catalog geometry for these purposes.

Re-use library can be leveraged to store probes in a library for use in new programs or to share these probes with other members of your team. CMM machine models can also be stored in the library and used in new projects.

NX CMM inspection analysis

Visualize With NX CMM's data analysis capabilities, you can quickly see and evaluate your "as-built" measurements in a graphical environment, right next to the "as-designed" models that drive your CMM

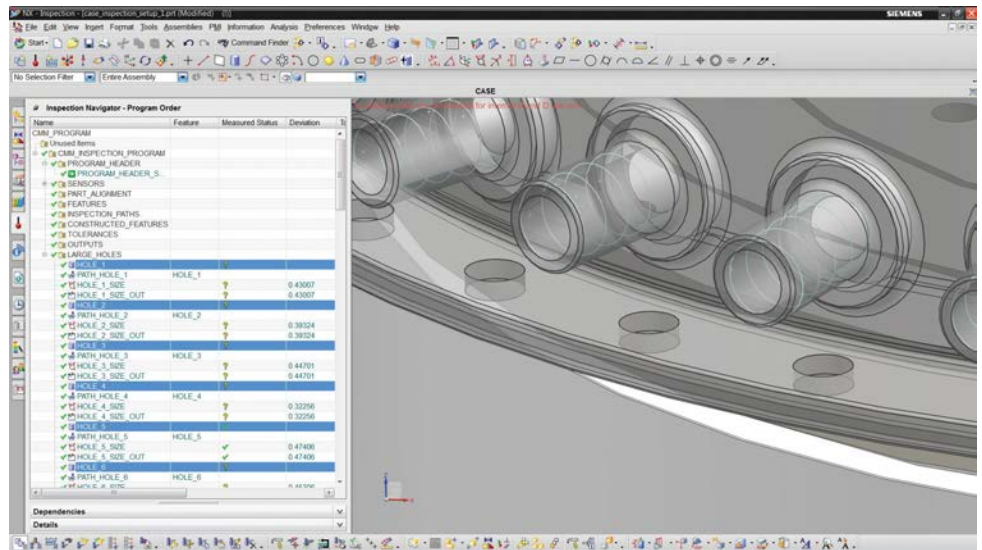

inspection programs. Putting the measurement results into context helps you find the most effective approaches to achieve quality improvements.

Analyze CMM measurements are read back into NX as .mea or .dml files. They are compared to the measured data, including the associated tolerances according to ANSI Y14.5, ASME Y14.5 or ISO 1011 standards. Measurements are displayed in the operation navigator as a list and linked to the graphical display for each measurement. Best-fit analysis and verification help you find the possible causes of tolerance failure and assist in decision-making that will improve component quality.

Integrated solution

Design change control enables you to use associativity to quickly update programs and immediately reflect design changes.

Process and data management enable you to leverage Teamcenter to ensure that you are always working with the correct file version, as well as to manage your data and processes. You can use these capabilities to easily share setups, programs and postprocessors with your entire team – regardless of a team member's geographic location.

NX CMM inspection program content

Machine types

Up to 3 linear axes

Standard catalog offerings

- Renishaw sensors
- Extensions and tips

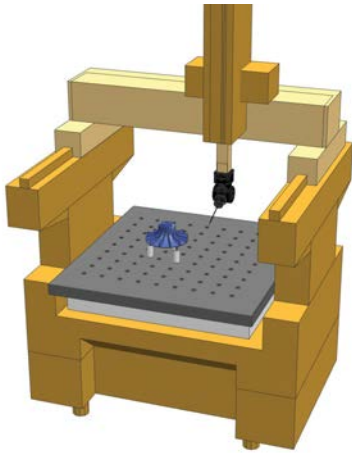

Output DMIS or create a custom postprocessor for a specific CMM.

Managed development environment

- Vaulting and version management of product and process data
- Web infrastructure for data accessibility
- Support for distributed concurrent team design

Online resources

Help documentation with tutorials

Automation

NX Open and Knowledge Fusion runtime package

Feature types

- Points
- Lines
- Planes
- Circles
- Arcs
- Cylinders
- Cones
- Torus
- Open slot/tab
- Closed slot/tab
- Spheres
- Surfaces
- Patterns
- Curves

Tolerance types

- Linear distance
- Diameter
- Radius
- Coordinate dimensions
- Width
- Angle between
- Cone angle
- Surface profile
- Line profile
- Datum definition
- Position symmetry
- Concentricity
- Angularity
- Perpendicularity
- Parallelism
- Circular runout
- Total runout circularity
- Flatness
- Cylindricity
- Straightness

Construction methods

- Best fit
- Intersection
- Projection
- Perpendicular-to
- Parallel-to
- Offset

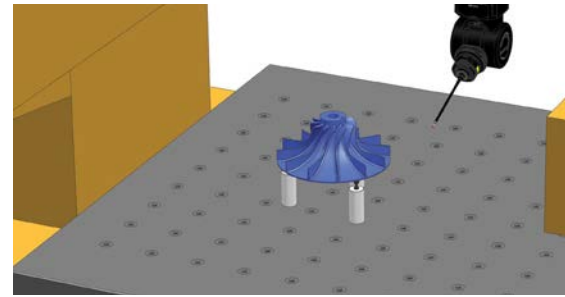

Leverage the machine environment to easily design holding fixtures.

Head types

- Fixed
- Indexable
- Variable

Probe types

- Straight
- Elbow
- Single-tip
- Multi-tip

Path types

- Points
- Scan line
- Scan curve
- Scan arc

Output language

- DMIS 5.2
- Custom

Translators

- DXF/DWG
- IGES
- STEP AP 203 and AP 214

Contact

Siemens Industry Software

Americas +1 800 498 5351

Europe +44 (0) 1276 702000

Asia-Pacific +852 2230 3333

www.siemens.com/plm